

TECHNICAL DATA

ENGINE, TRANSMISSION AND SUSPENSION

	2.7 TDV6 GS	3.0 TDV6 GS	3.0 TDV6 XS	3.0 TDV6 HSE
Six-speed manual transmission	■	–	–	–
Six-speed adaptive automatic transmission	□	■	■	■
Diesel Particulate Filter (DPF)*	□	□	□	□
Four-corner air suspension with Terrain Response®	■	■	■	■
Active rear locking differential	□	□	□	□

■ Standard □ Option – Not available

*LR-TDV6 3.0 Advanced Sequential Turbo Diesel engine EU5 compliant when fitted with a Diesel Particulate Filter (DPF)

TRANSMISSION

	2.7 TDV6 Manual	2.7 TDV6 Auto	3.0 TDV6 Auto
Transmission type	ZF S6-53	ZF HP26	ZF HP28
Gear Ratios (High range)			
6th	0.83	0.69	0.69
5th	1.0	0.86	0.86
4th	1.26	1.14	1.14
3rd	1.78	1.52	1.52
2nd	2.80	2.34	2.34
1st	5.08	4.17	4.17
Reverse	4.72	3.40	3.40
Final drive ratio	3.07	3.54	3.54
Transfer box ratio			
High	1:1	1:1	1:1
Low	2.93:1	2.93:1	2.93:1

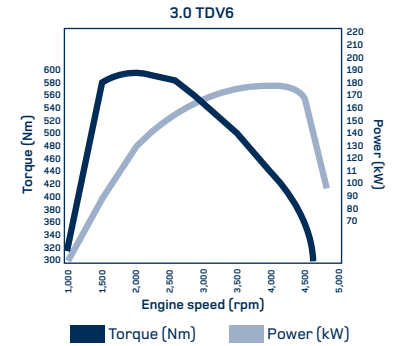

Max torque (Nm)
600Nm/2,000rpm

Max Power (kW)
180kW/4,000rpm

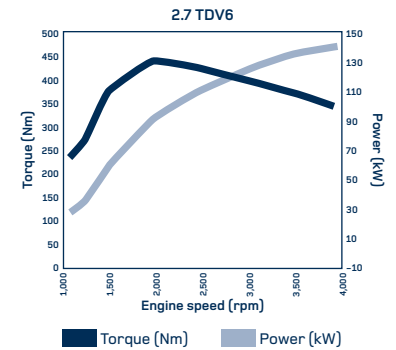

Max torque (Nm)
440Nm/1,900rpm

Max Power (kW)
140kW/4,000rpm

MAX SPEED IN GEARS

(High Range) mph (km/h) - Autos in 'D', with no CommandShift® or Sport selected			
	2.7 TDV6 Manual	2.7 TDV6 Auto	3.0 TDV6 Auto
1st	26.54 (42.71)	22.99 (36.99)	19 (30)
2nd	48.14 (77.46)	41.76 (67.19)	39 (63)
3rd	75.6 (121.64)	65.57 (105.5)	63 (101)
4th	106.99 (172.15)	92.74 (149.21)	85 (136)
5th	112 (180)	112 (180)	112 (180)
6th	112 (180)	112 (180)	112 (180)
(Low Range) - Autos in 'D', with no CommandShift® or Sport selected			
1st	9.06 (14.58)	7.85 (12.63)	6 (10)
2nd	16.42 (26.42)	14.24 (22.92)	14 (22)
3rd	25.82 (41.55)	22.36 (35.98)	21 (34)
4th	36.53 (58.78)	31.64 (50.91)	29 (46)
5th	46 (74.02)	39.88 (64.17)	39 (62)
6th	55.02 (88.52)	57.8 (93)	55 (88)
Cd (drag co-efficient)	0.41 (0.40 on 235/70R17)		

BRAKES

Description	2.7 TDV6	3.0 TDV6
Front size mm	317 (12.48)	360 (14.173)
Type	Ventilated disc	Ventilated disc
Rear size mm	325 (12.795)	350 (13.779)
Type	Ventilated disc	Ventilated disc
Parking	Duo Servo	Duo Servo

SAFETY & SECURITY

	2.7 TDV6 GS	3.0 TDV6 GS	3.0 TDV6 XS	TDV6 3.0 HSE
Roll Stability Control (RSC)	■	■	■	■
Airbags, row one driver and passenger front	■	■	■	■
Airbags, row one driver and passenger side	■	■	■	■
Airbags, side and head curtain (1st, 2nd & 3rd row*)	■	■	■	■
Central high mounted stop lamp	■	■	■	■
Dynamic Stability Control (DSC)	■	■	■	■
Electric Parking Brake (EPB)	■	■	■	■
Electronic Brake Assist (EBA)	■	■	■	■
Four channel all terrain ABS (Anti-lock Braking System) with all round ventilated disc brakes	■	■	■	■

■ Standard □ Option – Not available *3rd row only with 7 seats fitted

STEERING

	Description	All Derivatives
Type		Assisted rack and pinion
Steering wheel: height adjustment	standard	Turns lock to lock
Turning circle	Kerb to kerb Wall to wall	3.32 11.45m 11.8m

DIMENSIONS & CAPABILITY

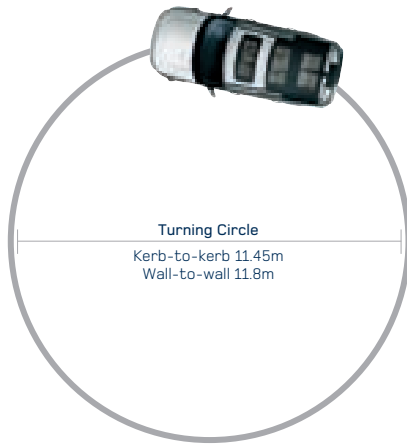

Obstacle Clearance
Ground clearance up to 310mm (12.20 in.)
(air suspension)
Standard ride height 185mm (7.28 in.)



Wading Depth
Maximum wading depth 700mm (27.56 in.) (air suspension)
Normal wading depth 600mm (23.62 in.)



Off-road Geometry	A	B	C
Approach Angle	36.2°	Ramp Break Over Angle	27.3°
Off-road ride height (air suspension)		Departure Angle	29.6°



Maximum load space – seats folded

Interior
Head room – mm (inch)
1st row 1,020 (40.2) (1,027 (40.4) with sunroof)
2nd row 1,043 (41.1) (1,076 (42.4) with sunroof)
3rd row 983 (38.7) (1,018 (40.1) with sunroof)
Leg room – mm (inch)
1st row 1,078 (42.4)
2nd row 955 (37.6)
3rd row 923 (36.3)
Shoulder room – mm (inch)
1st row 1,503 (59.2)
2nd row 1,499 (59)
3rd row 1,087 (42.8)



Maximum load space behind row 2 – seats up

Luggage Capacity
Load space length behind: – mm (inch)
1st row 1,950 (76.8) 7 seat (1,831 (72.1) 5 seat)
2nd row 1,124 (44.3) 7 seat (1,108 (43.6) 5 seat)
3rd row 338 (13.3) 7 seat
Width – mm (inch)
1,235 (48.6) (1,146 (45.1) between wheel arches)
Height – mm (inch)
1,027 (40.4) (1,058 (41.7) with sunroof)
Load space volume behind: – litres (cu. feet)
1st row 2,558 (90.3) 7 seat (2,476 (87.4) 5 seat)
2nd row 1,192 (42.1) 7 seat (1,260 (44.5) 5 seat)
3rd row 280 (9.9) 7 seat

WEIGHTS & PERFORMANCE

Width 2,022mm [79.6 in.] mirrors folded
2,176mm [85.7 in.] mirrors out



Rear wheel track 1,612.5mm [63.5 in.]



Wheelbase 2,885mm [113.6 in.]



Front wheel track 1,605mm [63.2 in.]



Length 4,838mm [190.1 in.]

Minimum height – mm (inch)

Roof options

Fixed roof

Alpine roof

With sunroof tilted open

Roof rails

Integrated phone antenna (Alpine roof)

Coil suspension Air suspension (in access lower mode)

1,887 [74.3] 1,837 [72.3]

1,882 [74.1] 1,832 [72.1]

1,920 [75.6] 1,870 [73.6]

1,891 [74.4] 1,841 [72.5]

1,938 [76.3] 1,888 [74.3]

WEIGHTS kg (lbs)

	2.7 TDV6 Manual	2.7 TDV6 Auto	3.0 TDV6 Auto
Base kerb mass* (weight from) (EU)	2,476 [5459]	2,486 [5481]	2,583 [5695]
Gross vehicle weight	3,180 [7011] - coil suspension 3,240 [7,143] - air suspension	3,180 [7011] - coil suspension 3,240 [7,143] - air suspension	3,240 [7143] - air suspension
Maximum mass on each axle (front)	1450 [3197]	1450 [3197]	1450 [3197]
Maximum mass on each axle (rear)	1840 [4057] - coil suspension 1,855 [4,090] - air suspension	1840 [4057] - coil suspension 1,855 [4,090] - air suspension	1855 [4090] - air suspension

Towing

Max towing (towing pack optional)	3,500 [7716]	3,500 [7716]	3,500 [7716]
Unbraked trailer	750 [1653]	750 [1653]	750 [1653]
Maximum mass of vehicle and trailer combination (GTW)	6,680 [14,727] - coil suspension 6,740 [14,859] - air suspension	6,680 [14,727] - coil suspension 6,740 [14,859] - air suspension	6,740 [14,859] - air suspension

*EEC kerb includes fluids, tools, spare and 75kg driver

PERFORMANCE AND FUEL ECONOMY

	2.7 TDV6 Manual	2.7 TDV6 Auto	3.0 TDV6 Auto
Maximum speed mph (km/h)	112 (180)	112 (180)	112 (180)
Acceleration - secs 0-60mph	11.0	11.7	9.0
0-100km/h	11.7	12.7	9.6

Fuel economy

Urban mpg (L/100km)	25.4 (11.1)	21.6 (13.1)	25.2 (11.2)
Extra urban mpg (L/100km)	34.9 (8.1)	33.2 (8.5)	34.0 (8.3)
Combined mpg (L/100km)	30.7 (9.2)	27.7 (10.2)	30.4 (9.3)
Combined CO ₂ emissions (g/km)	244	270	244
Drive by noise/dB	73.0	71.0	72.0 (non DPF) [†] 73.0 (DPF)

[†]DPF refers to Diesel Particulate Filter

Fuel consumption figures: The results given here do not express or imply any guarantee of the fuel consumption of any particular vehicle with which this information may be supplied. Vehicles are not individually tested and there are inevitable differences between individual vehicles of the same model. The vehicle may also incorporate particular modifications. Furthermore, the driver's style and road traffic conditions, as well as the extent to which the vehicle has been driven and the standard of maintenance, will affect its fuel consumption.